

**CAMERON BALLOONS LTD (THUNDER & COLT)
SERVICE BULLETIN**

Subject:

**THUNDER & COLT
STRATUS BURNER**

Title:

**Replacement of valve stems in the main blast, liquid fire
and pilot light valves.**

Parts affected:

**3 valve stems per block in valve blocks with serial
numbers:-**

0001 to 087, 089, 091 to 095, 097, 099, 100, 109, 117.

**(The serial number is engraved on each block and can be
seen when looking down through the coil).**

**Reason for
modification:**

**To ensure prevention of an external propane leak in the
event of valve stem or shutter mechanical failure.**

Classification:

Highly recommended.

Compliance:

**Within the next 20 flying hours or before 1st July 1996.
(which ever is sooner)**

Accomplishment:

Instructions:

**Complete the replacement procedure of sections A, B & C
on each affected Valve Block.
Complete section D on each affected Burner/Balloon.**

TOOLS PROVIDED

33mm A/F ring spanner.

Circlip pliers.

GE1002 Tube socket tool.

4mm A/F Allen key.

2.5mm A/F Allen key.

PTFE Paste (Finlon - M)

COMPONENTS (TO BE FITTED) PROVIDED

8511-0000 Pilot Valve Stem (1 per valve block).

8520-0000 Main Valve Stem (2 per valve block).

CU4872-3000 Stem O-Ring (3 per valve block).



Old Valve Stems to be removed



New Valve Stems to be fitted

MATERIALS REQUIRED

'Siliglide' Silicone spray lubricant (or equivalent brand).

GENERAL PROCEDURE

1. Before carrying out any disassembly on the burner ensure all pressure is vented from the burner and that the burner is disconnected from any fuel supply.
2. Ensure the burner is well supported before applying force to unscrew components.
3. Ensure all parts are kept clean during disassembly and reassembly. Ensure dirt or debris does not enter the valve block when valves are removed.
4. When the replacement is completed carry out a pressure test on the burner. Check carefully at each valve for any sign of a leak at the valve stem or around the valve housing. If any leak is observed it must be prevented by fitting new seals.
5. Briefly check each valve for correct functioning.

SECTION A Assy No. B5-292A

MAIN BLAST VALVE (Refer to Figure B5A)

STAGE 1

Using a 4mm A/F Allen Key remove handle retaining bolts (CY0005-0025) and remove handle (8529-0000).

STAGE 2

Push pivot pin (8527-0000) out of trigger (8566-0000), taking care to retain the small spring (8602-0000) and pivot pin. Remove the trigger.

STAGE 3

Slip the boss (8528-0000/8524-0000) off the valve bonnet (8523-0000). Using a 33mm A/F spanner and taking care not to scratch the face of the valve block, loosen the bonnet. This may require some force and tapping the spanner with a mallet may be necessary. Unscrew the valve.

STAGE 4

Carefully withdraw the shutter (8601-0000) and stem (8520-0000) from the valve bonnet.

STAGE 5

Remove the white PTFE ring (CU7553-0011) from the old stem. Discard the old stem. Fit a new black O-ring (CU4872-3000) and the reused white PTFE ring onto the new stem. Note the correct order for these rings on the stem as shown in the illustration.

STAGE 6

Lubricate the new stem with Siliglide and carefully insert into the valve bonnet, taking care not to disturb the PTFE spring seal (CA0000-8214), or to damage the black O-ring seal. Refit the washer (CY0008-2008) spring (CU7553-0009) and shutter (8601-0000).

STAGE 7

Apply some fresh PTFE paste to the end face and screw thread of the valve bonnet. Ensure the copper washer (CA0000-8226) is in position in the valve block. Screw the valve assembly back into the valve block and tighten.

STAGE 8

Refit the boss (8528-0000/8524-0000). Refit the trigger remembering to locate the small spring (8602-0000).

STAGE 9

Repeat procedure of stages 2 to 8 for each main blast valve in turn.

STAGE 10

When all the main blast valves have been modified refit the handle (8529-0000). Refit all the handle retaining bolts (CY0005-0025) and tighten.

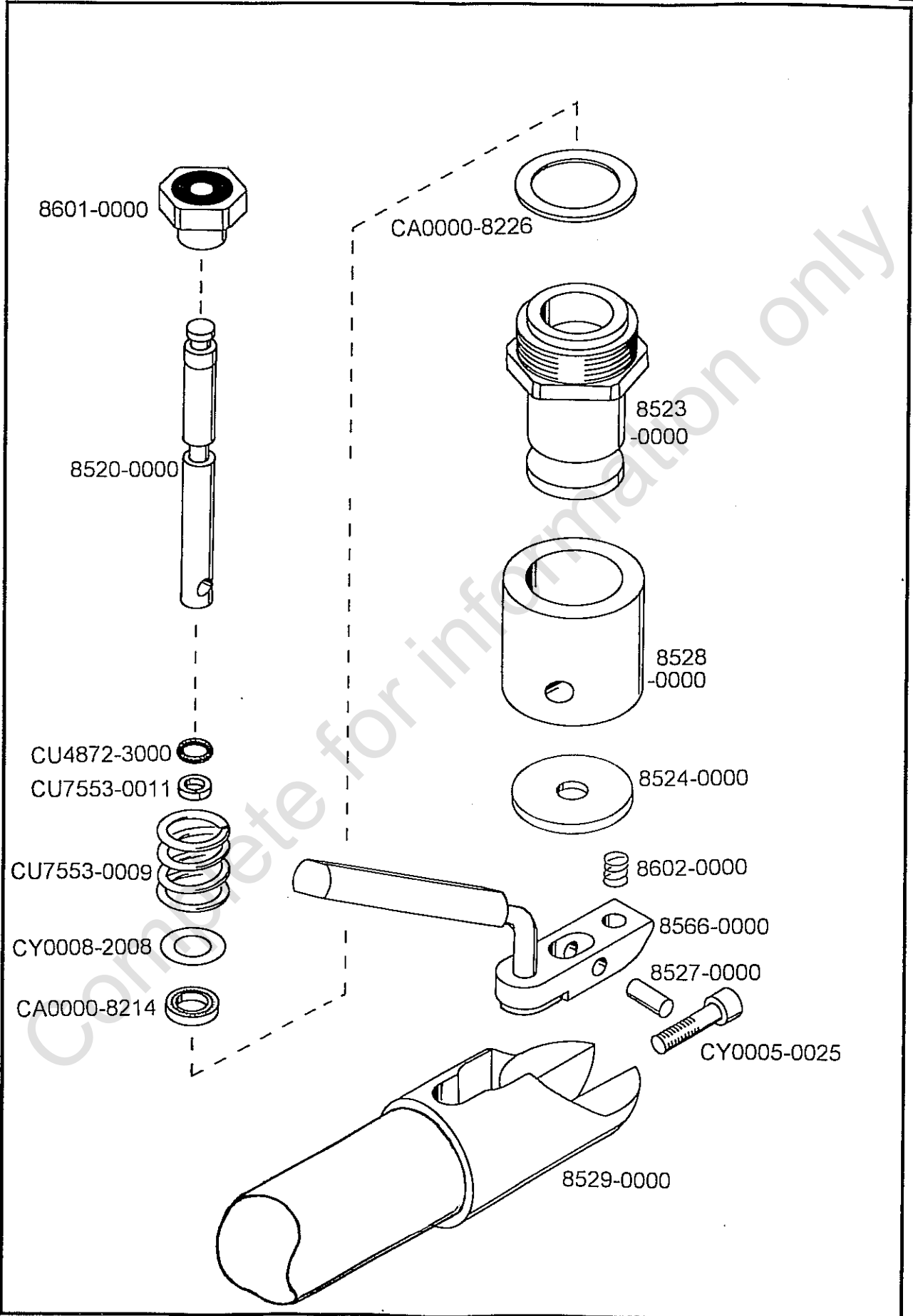

SECTION B Assy No. B5-293A

LIQUID FIRE VALVE (Refer to figure B5B)

STAGE 1

Using a 33mm A/F spanner and taking care not to scratch the face of the valve block, loosen the valve bonnet (8521-0000). This may require some force and tapping the spanner with a mallet may be necessary. Unscrew the valve.

STAGE 2

Using a pair of circlip pliers carefully remove the small circlip (CA0000-8300) from the pivot pin (CA0000-8299). Slip the pivot pin out of the toggle handle (8522-0000) and remove the toggle handle.

STAGE 3

Carefully withdraw the shutter (8601-0000) and stem (8520-0000) from the valve bonnet.

STAGE 4

Remove the white PTFE ring (CU7553-0011) from the old stem. Discard the old stem. Fit a new black O-ring (CU4872-3000) and the reused white PTFE ring onto the new stem. Note the correct order for these rings on the stem as shown in the illustration.

STAGE 5

Lubricate the new stem with Siliglide and carefully insert into the valve bonnet, taking care not to disturb the PTFE spring seal (CA0000-8214), or damage the black O-ring seal. Refit the washer (CY0008-2008) spring (CU7553-0009) and shutter (8601-0000).

STAGE 6

Apply some fresh PTFE paste to the end face and screw thread of the valve bonnet. Ensure the copper washer (CA0000-8226) is in position in the valve block. Screw the valve assembly back into the valve block and tighten.

STAGE 7

Check the wear pad (CA0000-8227) is in position. Refit the toggle handle (8522-0000), pivot pin (CA0000-8299) and circlip (CA0000-8300).

STRATUS - LIQUID FIRE

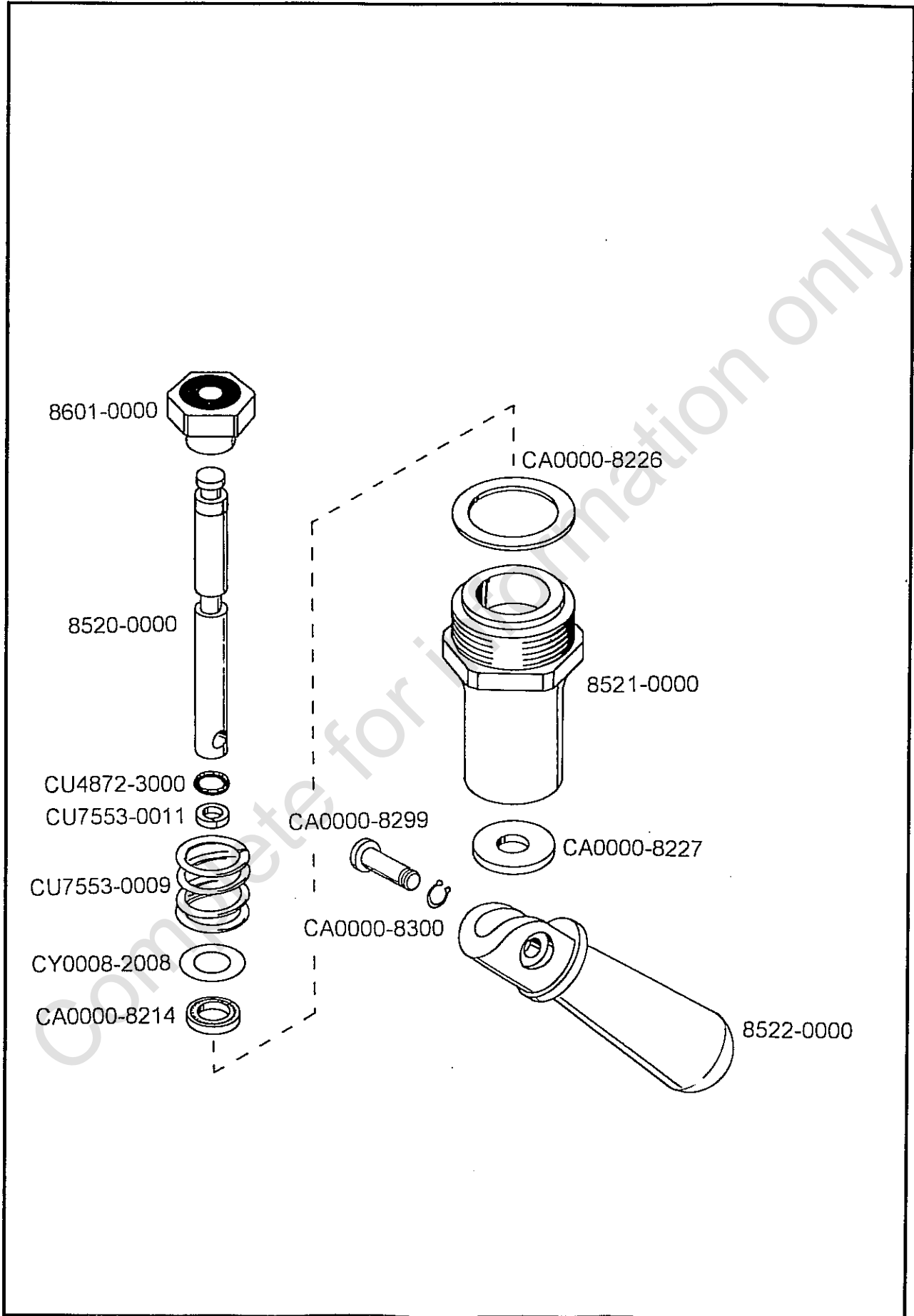

THUNDER & COLT

SECTION C Assy No. B5-291A

PILOT VALVE (Refer to figure B5C)

STAGE 1

Using a 2.5mm A/F Allen key remove the pilot lever (8514-0000) and knob (8513-0000).

STAGE 2

Using pliers remove the dowel pin (8515-0000) from the valve block.

STAGE 3

Using socket tool GE-1002 unscrew the pilot valve nut (8512-0000).

STAGE 4

Carefully withdraw the valve shutter (8538-000) and stem (8511-0000) from the pilot valve nut.

STAGE 5

Remove the white PTFE ring (CU7553-0011) from the old stem. Discard the old stem. Fit a new black O-ring (CU4872-3000) and the reused white PTFE ring onto the new stem. Note the correct order for these rings on the stem as shown in the illustration.

STAGE 6

Lubricate the new stem with Siliglide and carefully insert into the valve nut, taking care not to damage the black stem O-ring. Refit the spring (8516-0000) and shutter (8538-0000).

STAGE 7

Screw the valve assembly back into the valve block and tighten with tool GE-1002.

STAGE 8

Refit the dowel pin (8515-0000) into the valve block.

STAGE 9

Using the bolt (CY0003-0016) refit the knob and lever into the valve stem and tighten.

SECTION D

On completion of the Valve Stem replacements in all Valve Blocks of the burner, and successful pressure test, record the embodiment of SB in the balloon log book.

